

ORIGINAL ARTICLE

Alterations of the MDV oncogenic regions in an MDV transformed lymphoblastoid cell line

E Le Rouzic, P Thoraval, M Afanassieff, Y Cherel, G Dambrine, B Perbal

J Clin Pathol: Mol Pathol 2002;**55**:262–272

Aims: Lymphoblastoid cell lines derived from Marek's disease virus (MDV) induced tumours have served as models of MDV latency and transformation. They are stable and can be cultured with no detectable MDV genomic alterations upon repeated passaging. An MDV transformed lymphoblastoid T cell line (T9 cell line) has been reported to contain a disrupted MDV BamHI-H fragment and a Rous associated virus insertional activation of the c-myc protooncogene. In an attempt to define the respective participation of c-myc and MDV in the transformed phenotype of T9 cells, an analysis of MDV oncogenic sequences (BamHI-H, BamHI-A, and EcoQ fragments) was performed in these cells.

Methods: Using two different passages of the T9 cell line (late and early passages), the organisation of the MDV oncogenic regions and their expression in these cells were analysed. In vivo assessment of the oncogenicity of the virus contained within these cells was assessed by injecting them into 1 day old chickens.

Results: In T9 cells maintained in culture for up to six months (late T9), the MDV ICP4 gene was disrupted, whereas the meq gene was actively transcribed. The alterations of the MDV genome in these cells correlated with the inability of the virus to induce the classic signs of Marek's disease in 1 day old chickens. However, early T9 cells submitted to a limited number of passages induced classic MDV pathogenicity, as efficiently as the MDV control cell line (T5), and did not show gross structural changes in the oncogenic MDV sequences.

Conclusions: Although the expression pattern of the MDV oncogenes in early T9 cells was identical to the one reported for other MDV transformed cells, longterm culture of an MDV transformed cell line containing a RAV insertional activation of the c-myc protooncogene led to the disruption of the MDV BamHI-H and BamHI-A oncogenic regions. In the late T9 cells MEQ was the only detected MDV oncoprotein. These results suggest that in the late T9 cells the truncated MYB protein compensates for the loss of MDV oncoproteins and reinforce the possibility that MEQ and MYB cooperate in the maintenance of the transformed state and the tumorigenic potential of these cells.

See end of article for authors' affiliations

Correspondence to:
Professor B Perbal, UFR de Biochimie, Université Paris 7-D. Diderot, 2 Place Jussieu, 75005 Paris, France;
Bernard.Perbal@wanadoo.fr

Accepted for publication
8 May 2002

This manuscript is dedicated to the memory of Pierrick.

Marek's disease virus (MDV) is an avian herpesvirus that causes T cell lymphomas and mononuclear infiltration in peripheral nerves, leading to paralysis within four to six weeks in susceptible chickens.¹ The MDV genome, co-linear with α herpesvirus genomes, is 180 kb long and consists of short and long unique regions (U_s and U_l , respectively), flanked by terminal repeats (TR_l and TR_s , respectively), and internal repeats (IR_l and IR_s , respectively).^{2–4}

The rapid onset of tumours suggests the presence of MDV encoded oncogene(s). However, little is known about the molecular mechanisms of MDV induced oncogenesis. Several experimental approaches have been taken to identify viral genes that may be involved in the process of oncogenesis. These approaches include the analysis of: (1) the regions of the MDV genome that undergo alteration during attenuation of oncogenic strains (serotype 1); (2) the viral gene products expressed in MDV induced tumours and tumours derived from lymphoblastoid cell lines; and (3) the viral gene products of the serotype 1 strain, which are absent in the non-oncogenic serotype 2 MDV and serotype 3 herpesviruses of turkey strains. At least 15 open reading frames (ORFs) mapping mainly within four BamHI fragments (BamHI-H, BamHI-I₂/Q₂, and BamHI-A) spanning the IR_l and the IR_s are expressed in transformed lymphocytes.⁵

"Much evidence has accumulated to suggest that MEQ might play a role in oncogenesis: it is consistently expressed in most MDV infected cells, in transformed cell lines, and in CD4+ T cells from lymphomas"

Initially, it was noted that serial in vitro passages of oncogenic MDV strains in primary chicken embryo fibroblasts (CEFs) led to a loss of tumorigenicity.^{6–8} This change was shown to be associated with the amplification (up to 100 copies) of a 132 bp repeat within the BamHI-H and BamHI-D fragments.^{9–10} In lymphoblastoid cell lines carrying attenuated MDV strains, this amplification results in the expression of truncated RNA species from the 1.8 kb family.¹¹ Kawamura *et al* have reported that oligonucleotides complementary to the predicted splice donor site in the 1.8 kb family inhibit proliferation of MDV cell lines.¹² The transfection of CEFs with two cDNAs isolated from this family of transcripts resulted in reduced serum dependence and prolonged proliferation of these cells.¹³ Four alternatively spliced and unspliced RNAs spanning the 132 bp repeat have been identified in CEFs infected with an oncogenic MDV strain, and at least two ORFs have been characterised, although their function remains unclear.^{14–15} Another protein, the phosphoprotein pp38, is expressed from this region. Its gene is transcribed in the opposite orientation and overlaps the U_l and IR_l junction. The

Abbreviations: CEF, chicken embryo fibroblast; GAPDH, glyceraldehyde-3-phosphate dehydrogenase; IR_l , long internal repeat; IR_s , short internal repeat; LATs, latency associated transcripts; MDV, Marek's disease virus; MHC, major histocompatibility complex; ORF, open reading frame; PBS, phosphate buffered saline; RAV-2, Rous associated virus 2; TAE, Tris acetate EDTA; TR_l , long terminal repeat; TR_s , short terminal repeat; U_s , short unique region; U_l , long unique region

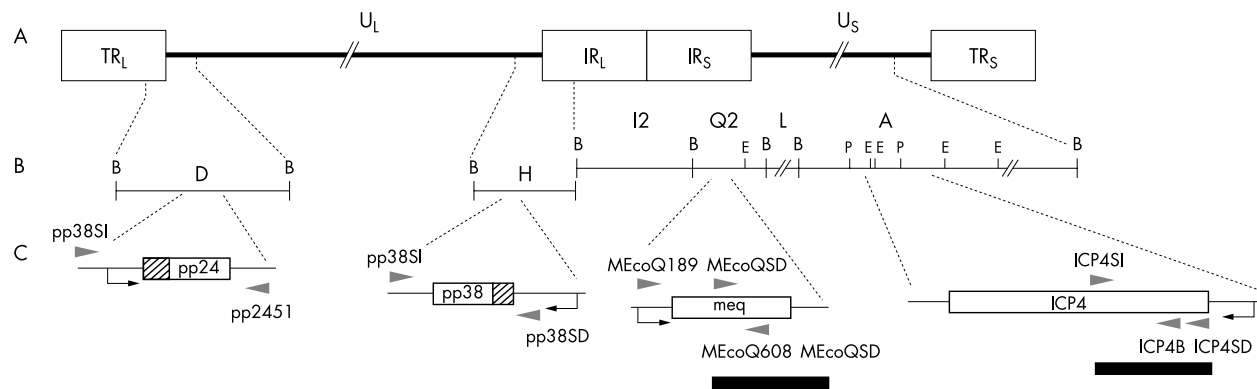

Figure 1 (A) Genomic structure of Marek's disease virus (MDV). MDV consists of long and short unique sequences (U_L and U_S , respectively), flanked by long and short internal repeats (IR_L and IR_S , respectively), and long and short inverted terminal repeats (TR_L and TR_S , respectively). (B) Locations of the BamHI-D, BamHI-H, BamHI-I2, BamHI-Q2, BamHI-L, and BamHI-A regions. A detailed restriction map is indicated (E, EcoRI; B, BamHI; P, PvuII). (C) Locations of the pp24, pp38, meq, and ICP4 homologue genes. Corresponding gene regions are enlarged to show the open reading frame and the transcription sense (arrow); the localisations of the oligonucleotides (arrowhead) used for PCR and Southern blotting are indicated. A solid bar represents the resulting amplified product used as a probe.

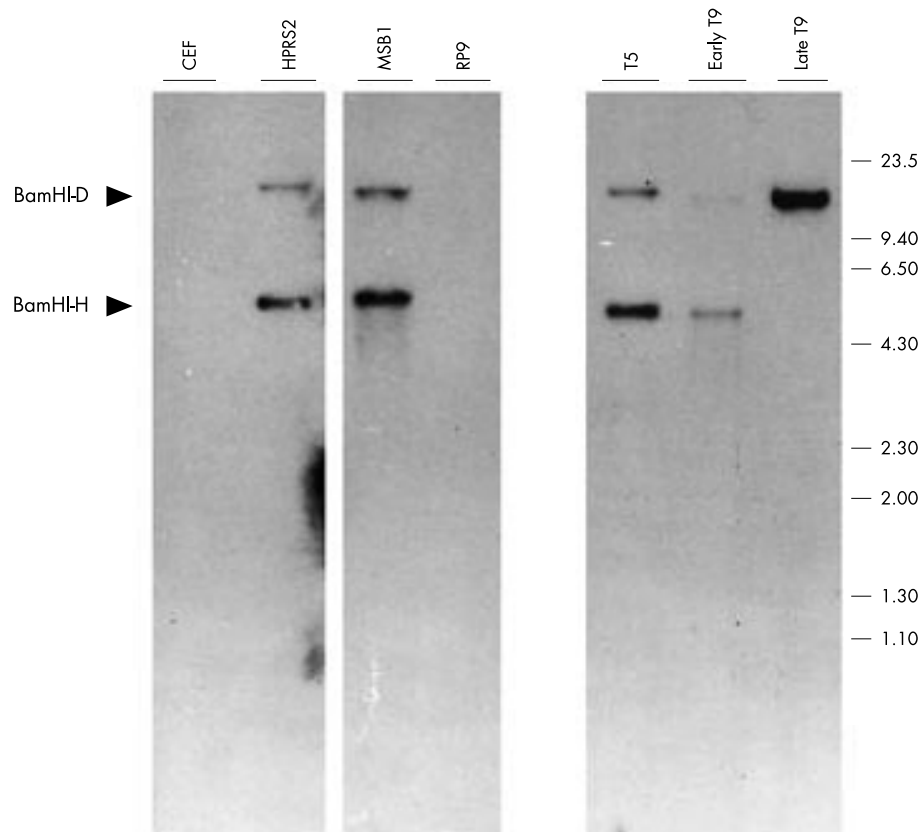

Figure 2 Disruption of Marek's disease virus (MDV) BamHI-H fragment in late T9 DNA. Southern blots of BamHI digested high molecular weight DNA (15 μ g) were hybridised with the [32 P] labelled MDV specific 5.4 kb BamHI-H probe.¹⁰ DNA samples from chicken embryo fibroblasts (CEFs) were used as negative control. Molecular weight markers (in kilobases) are from HindIII digested λ DNA.

BamHI-D fragment encodes a phosphoprotein, pp24, the transcripts of which overlap TR_L and U_L .¹⁶ Both of these proteins are expressed in lytically infected cells and at a lower degree in lymphoblastoid cell lines.¹⁷ The use of antisense strategies suggested that pp38 might play a role in the proliferation of the MDV transformed cell line, MSB-1.^{12, 18}

The MDV ICP4 gene maps to the BamHI-A fragment, within the IR_S flanking the U_L region of the MDV. It encodes an immediate-early transactivator that plays a crucial role in the regulation of transcription during MDV replication.^{19, 20} Oligonucleotides complementary to the translation start region of ICP4 and the expression of antisense RNA inhibited the

growth of MSB1 cells, indicating that the ICP4 gene might be required for the maintenance of the transformed state.¹⁸ Latency associated transcripts (LATs) expressed in lymphoblastoid cell lines and lytically infected CEFs²¹⁻²³ are complementary to ICP4. It has been suggested that the LATs could regulate the expression of ICP4 and thus contribute to transformation by preventing replication of the virus.²⁰

The best characterised candidate MDV oncogene is the EcoRI-Q protein (MEQ), which is expressed from the adjacent BamHI-I2 and BamHI-Q2 fragments in the IR_L . Much evidence has accumulated to suggest that MEQ might play a role in oncogenesis: it is consistently expressed in most MDV infected

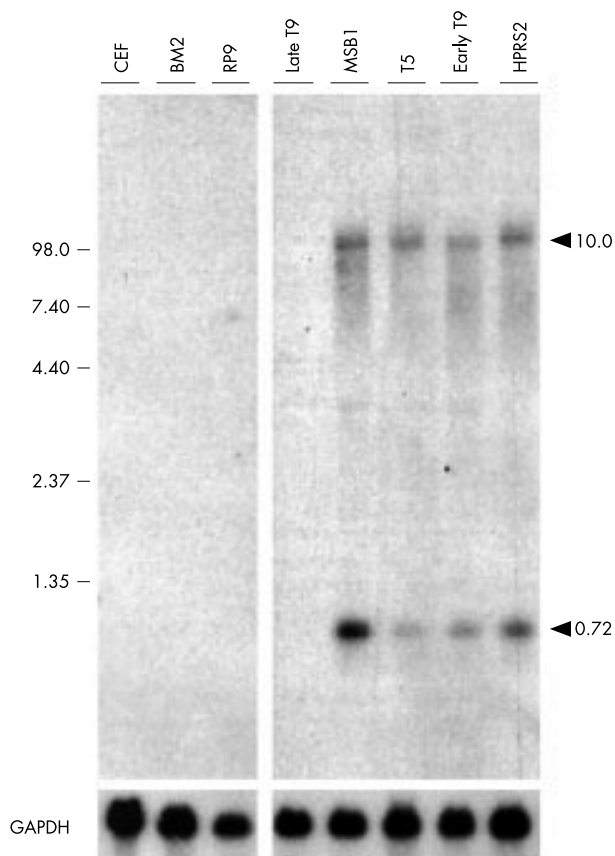

Figure 3 Analysis of the ICP4 gene region. Expression of RNA species in Marek's disease virus (MDV) transformed cell lines. Northern blots were performed with 20 µg samples of total RNA, and were sequentially probed with [³²P] labelled ICP4 and glyceraldehyde-3-phosphate dehydrogenase (GAPDH) double strand fragments. Chicken embryo fibroblasts (CEFs) and BM2 RNA samples were used as negative controls. Size markers in kilobases correspond to the BRL RNA ladder.

cells, in transformed cell lines, and in CD4+ T cells from lymphomas.²⁴⁻²⁶ The expression of RNA complementary to meq can prevent the growth of the MSB1 cell line,¹⁸ and overexpression of meq in rat-2 fibroblasts by recombinant murine retrovirus led to cell transformation.²⁷ The MEQ protein is a transactivating b-Zip protein that homodimerises or heterodimerises in vitro with c-Jun, c-Fos, and cAMP response element binding protein.²⁴⁻²⁸⁻³⁰ It has antiapoptotic activities,²⁷ and was proposed to promote cell cycle progression.²⁸ However, MEQ alone is not capable of transforming primary CEFs and the injection of chickens with replication defective virus carrying meq yielded a low incidence of sarcomas (5%), which eventually metastasised into internal organs.²⁷

Altogether, these observations indicated that none of the viral genes is sufficient on its own for the induction and/or the maintenance of transformation of lymphoid cells in Marek's disease. The close relation seen in the regulation of their expression suggested a synergistic action between these different viral genes. The pp38 promoter contains an ICP4 responsive element and transfection of MSB-1 cells by an ICP4 expression plasmid correlates with overexpression of the pp24 and pp38 phosphoproteins.³¹ The MEQ homodimer can bind to at least two distinct motifs (MERE I and II). A MERE II element is present in the putative MDV origin of replication, which overlaps the bidirectional promoter of the pp38 gene and the 1.8 kb family gene.³⁰

We have previously reported that, in addition to an altered MDV BamHI-H fragment, the MDV transformed T9 cells also contained a c-myb insertional activation. These results sug-

gested that the maintenance of the transformed state was dependent upon the presence of a truncated c-MYB protein.³² To test this hypothesis, we analysed the putative oncogenic regions from the MDV in the T9 cell lines. Here, we report that, except for the meq gene, MDV regions encoding putative oncogenes are altered in T9 cells, therefore raising the possibility that maintenance of transformation in this cell line might require cooperation between the meq and truncated myb oncogenes.

MATERIALS AND METHODS

Cells

The T9 and T5 T cell lymphoma cell lines were isolated from two testicular tumours obtained after the injection of MDV (HPRS16 strain) into 1 day old white leghorn chickens. The injection of T9 and T5 cells into chickens induced Marek's disease at the time the cell lines were established. T cell antigens have been characterised on the surface membrane of T9 cells³³ and the T9 cell line has been used in cytotoxicity assays.³⁴ The two other Marek's disease cell lines were isolated in different laboratories: MDCC-MSB1 was derived from a splenic lymphoma³⁵ and HPRS2 was derived from an ovarian lymphoma.³⁶ The RP9 cell line was established from a Rous associated virus 2 (RAV-2) induced B transplantable lymphoma.³⁷ These cell lines were grown in RPMI 1640 medium supplemented with 10% fetal calf serum. The BM2 myeloblastic cell line was obtained from a chicken infected with avian myeloblastosis virus.³⁸ BM2 cells were grown in DMEM medium supplemented with 10% fetal calf serum, 10% tryptose phosphate broth, and 2% heat inactivated chicken serum. CEFs were prepared from 13 day old C/E brown leghorn embryos (gs+, chf+, V-) of the Edinburgh strain, and cultured as described elsewhere.³⁹ All cultures were performed at 37°C in a 5% CO₂ atmosphere.

In vivo infectivity assays

The GB1 strain of inbred chickens bearing the major histocompatibility complex (MHC) haplotype B13 was used in these studies.⁴⁰ These chickens were free from specific pathogens, lacked maternal antibodies directed against MDV, and were highly susceptible to Marek's disease. At hatching, three groups of chickens were injected intraperitoneally with 10⁷ T5 or T9 cells. In each group, eight to nine chicks were injected and six were used as internal controls to assess the horizontal transmission of MDV. Birds were euthanised and necropsied upon signs of morbidity. Organs with Marek's disease lesions were harvested, processed for histological examination, and frozen for subsequent DNA isolation. Histological examinations of the nerves were systematically performed.

Southern blot analysis

High molecular weight DNA was purified from primary cells, cell lines, and solid tumours as described previously.⁴¹ After restriction endonuclease (GIBCO-BRL, Cergy Pontoise, France) digestion and electrophoresis in horizontal 0.8% TAE (Tris/acetate/EDTA electrophoresis buffer) agarose gels, DNA fragments were transferred on to Nytran membranes (Schleicher and Schuell, Dassel, Germany). Hybridisation to [³²P] labelled probes was performed as described elsewhere.⁴¹ All probes were prepared from purified DNA inserts.

RNA purification and analysis

Total RNA was prepared from cultured cells, using the guanidinium isothiocyanate method and northern blotting analysis was performed under the conditions described previously.⁴¹

Polymerase chain reaction

DNA from whole cellular lysates, prepared as described,⁴² and purified high molecular weight DNA were subjected to polymerase chain reaction (PCR) amplification using Taq DNA polymerase (Appligene, Paris, France) in a Perkin-Elmer Cetus

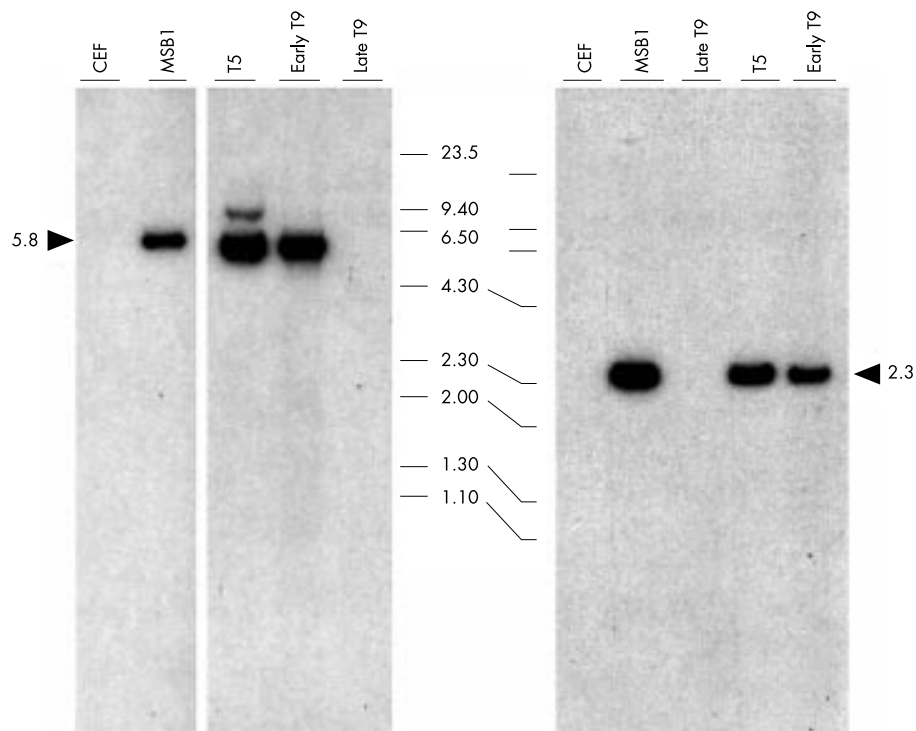

Figure 4 Analysis of the ICP4 homologue gene region. Southern blot analysis. DNA (15 µg) digested with EcoRI (left hand panel) or PvuII (right hand panel) from the indicated cells was run on a 0.8% agarose gel and then blotted and hybridised with the ICP4 probe. Molecular weight markers (in kilobases) are from HindIII digested λ DNA. CEF, chicken embryo fibroblast.

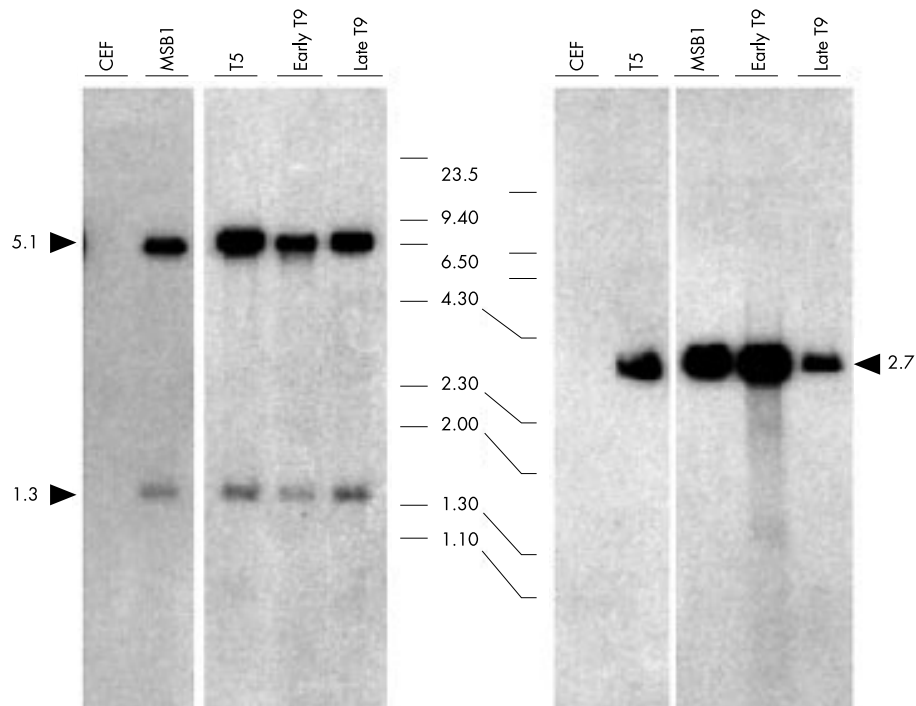

Figure 5 Analysis of the Eco-Q region encoding the meq gene. Southern blot analysis. DNA (15 µg) digested with BamHI (left hand panel) or EcoRI (right hand panel) from the indicated cells was blotted and hybridised with the meq probes. Chicken embryo fibroblast (CEF) and RP9 digested DNA samples were used as negative controls. Molecular weight markers (in kilobases) are from HindIII digested λ DNA.

thermocycler. PCR conditions were as described previously.³² The primers for the pp38 gene used for amplification were as follows (5' to 3'): pp38SD, GCTGCAGCTGTCCATTTTCC; pp38SI, GCCATCCTTGCTTTCTGACC; and pp38LI, CTGCTCGAATTCAC-CACC (nt 1529 to 1549, 2564 to 2584, and 2500 to 2519,¹⁰

respectively). The primer for the pp24 gene was as follows: pp24SI, ACCCCGTAACCAGCATGATG (nt 1411 to 1431³³). The primers for the ICP4 gene were as follows: ICP4SI, GCCATGGGATGTGTGAATCT; ICP4SD, CAACGCCAATATGGACGATGA; and ICP4B, TGAGACTTCACCGTCAAATG (nt 1395 to

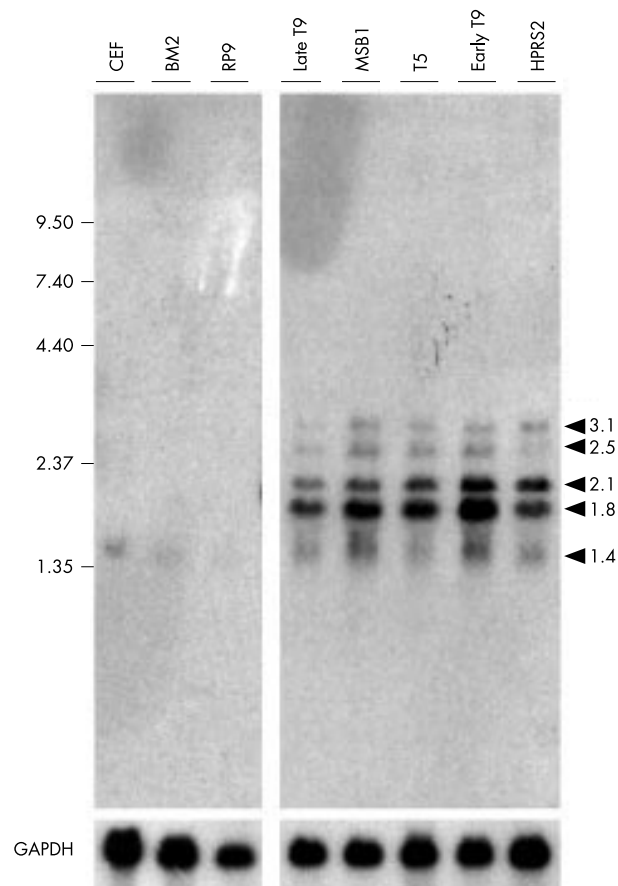

Figure 6 Analysis of the Eco-Q region encoding the meq gene. The expression of meq RNA species in Marek's disease virus transformed cell lines. Northern blots were performed with 20 µg samples of total RNA from the indicated cells, and were sequentially hybridised with [³²P] labelled probes meq and glyceraldehyde-3-phosphate dehydrogenase (GAPDH) double strand fragments. Chicken embryo fibroblast (CEF) and BM2 RNA samples were used as negative controls. The size markers (in kilobases) correspond to the BRL RNA ladder.

1415, 2224 to 2244, and 1638 to 1657,¹⁹ respectively). The primers for the meq gene were as follows: MEcoQSD, ACATTGCTCCGGTCCCAAC; MEcoQSI, ATAGACGATGTGCTGCTGAG; and MEcoQ, TATGGGGAGTAGAGATGGGA (nt 843 to 862, 1392 to 1411, and 933 to 952,²⁴ respectively). PCR products were separated on TAE agarose gels and analysed by Southern blot hybridisation with labelled internal oligonucleotide probes (pp38I, ICP4B, and MECoQ), as described previously.⁴¹

Nucleic acid probes

DNA fragments were GeneClean (Bio101) purified, and labelled with [³²P] dCTP (ICN, Orsay, France) by nick translation (Invitrogen, Cergy Pontoise, France). The MDV specific probe corresponded to the BamHI-H fragment localised at the junction between the U_L and IR_L.¹⁰ The meq and ICP4 DNA probes were obtained from PCR amplified fragments using DNA isolated from the MSB1 cell line and specific oligonucleotides (fig 1). The PCR products were sequenced and cloned in the pMOSBlue plasmid vector (Amersham, Orsay, France). Avian glyceraldehyde-3-phosphate dehydrogenase (GAPDH)⁴⁴ was used as an internal standard to assess the amount of RNA present in each sample.

Immunoblot assays

Cells were lysed in RIPA buffer (50 mM Tris/HCl, pH 8.0, 150mM sodium chloride, 0.1% sodium dodecyl sulfate, 0.5% sodium deoxycholate, 1.0% NP40, and 5mM EDTA); 5 µg/ml of leupeptin, antipain, chymostatin, pepstatin; 0.4 TIU of aprotinin/ml (trypsin inhibiting units); and 2mM of aminoethyl-benzenesulfonyl fluoride (Sigma, Saint Quentin Fallavier, France). Lysates were clarified by centrifugation at

10 000 ×g for 15 minutes at 4°C and supernatants were stored frozen at -70°C until analysis. Samples of protein extracts solubilised in Laemmli buffer were separated by sodium dodecyl sulfate-polyacrylamide gel electrophoresis and electroblotted on to a PVDF membrane (Immobilon P; Millipore, Strasbourg, France). Filters were incubated overnight at 4°C in phosphate buffered saline (PBS) containing 4% non-fat dried milk and 0.05% Tween 20, before probing with the appropriate antiserum for one hour at 37°C. Filters were rinsed three times in PBS containing 0.05% Tween 20 for 10 minutes and then incubated with horseradish peroxidase conjugated goat anti-rabbit antibodies. The proteins were detected by the enhanced chemiluminescence method (ECL), under the conditions recommended by the manufacturer (Amersham).

RESULTS

Structure of the BamHI-H and BamHI-D fragments in the MDV T cell lines

The T9 cells were serially maintained in culture and passaged for up to six months. Both low number (early T9) and high number passage stocks (late T9) were used in our study.

When PCR was performed with the pp38SI and pp38SD primer set a 1.0 kb DNA fragment was amplified from MSB1, T5, and early T9 DNA (not shown). No amplification was observed with late T9 and CEF DNA. Because BamHI-H and BamHI-D share the same sequence within TR_L and IR_L, amplification of the pp24 gene fragment could be performed with pp38SI and the pp24SI primer specific for the 3' proximal coding region of the pp24 gene (fig 1). A 0.8 kb fragment was amplified from the DNA of all MDV cell lines (not shown). No amplification was observed for CEF DNA.

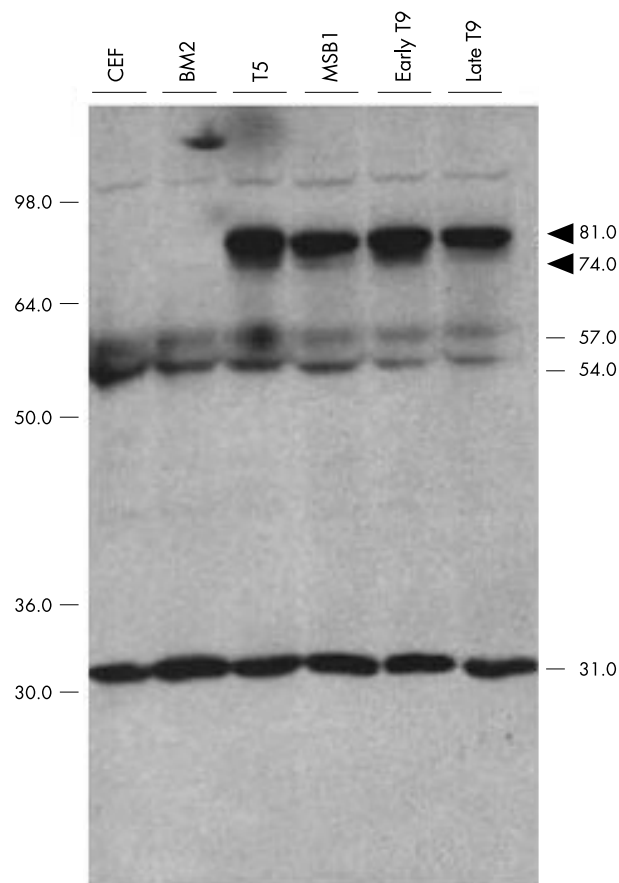

Figure 7 Analysis of the Eco-Q region encoding the meq gene. The expression of MEQ proteins in Marek's disease virus (MDV) transformed cell lines. Proteins (100 µg) were denatured in Laemmli buffer and then resolved on 10% sodium dodecyl sulfate-polyacrylamide gel electrophoresis before transferring on to a PVDF membrane. The blot was probed with rabbit anti-MEQ polyclonal antibodies (1/3000 dilution²⁷), followed by detection using the enhanced chemiluminescence (ECL) system (Amersham). Cell extracts from chicken embryo fibroblasts (CEFs) and BM2 were used as negative controls. Specific MDV products are indicated by arrows. Prestained molecular weight markers (Novex) are indicated in kilodaltons.

Table 1 Induction of Marek's disease following injections of T5 and T9 cell lines

Cellular strains	Age at necropsy (weeks)	Chickens with macroscopic lesions/injected ones (%)	Chickens with macroscopic lesions/contact ones (%)
T5	11	4/8 (50)	4/6 (66)
Early T9	6–8	8/9 (88)	5/6 (83)
Late T9	6–13	0/9 (0)	0/6 (0)

Southern blot hybridisation performed with the BamHI fragment H as probe detected a 5.4 kb and a 12 kb BamHI fragment in early T9, T5, HPRS2, and MSB1 DNA, corresponding to the BamHI-H and BamHI-D fragments, respectively (fig 2),⁴⁵ but not in the CEFs or in RP9 RAV transformed cells. The 5.4 kb BamHI-H fragment was not detected in late T9 cells, although the 12 kb fragment was still present, a result in agreement with amplification of the pp24 gene (fig 2, right hand panel). These results indicated that the BamHI-D fragment containing the pp24 gene was present in both early and late T9 cell DNA, and that the BamHI-H fragment is disrupted in the late T9 cells.

Structure and expression of the region containing the ICP4 gene and LATs in the MDV cell lines

The IR_s contains the 5' part of the BamHI fragment A, which encodes the immediate-early ICP4 gene.¹⁹ A specific fragment of the ICP4 gene obtained by PCR was used as a probe (fig 1).

Northern blotting using the ICP4 PCR product as a probe revealed that transcripts of 0.72 and 10.0 kb were expressed in MSB1, HPRS2, T5, and early T9 cell lines (fig 3). As previously reported, these RNA species resulted from antisense transcription of the ICP4 locus.^{21–23} No ICP4 RNA species were detected from either late T9 cells or from cells that are not transformed by MDV (CEF, BM2, and RP9).

Hybridisation of EcoRI digested high molecular weight DNA with the ICP4 DNA probe detected a 5.8 kb DNA fragment in T5, MSB1, and early T9 cell lines (fig 4, left hand panel). No fragments were detected by this probe in late T9 cells DNA. In early T9 cells, this probe revealed an additional, but less intense band corresponding to a 6.8 kb DNA fragment. As expected from the previously published nucleotide sequence,^{19–46} the same probe detected a 2.3 kb fragment in the PvuII digested DNA from the T5, early T9, and MSB1 cell lines (fig 4, right hand panel).

Table 2 Effects of Marek's disease virus cell lines inoculated into 1 day old B13 chickens

Cell lines	No. chickens	Date of sacrifice (or death*)	Tumour localisation	Other disorders
T5 inoculated chickens	955	11*	(1) Heart	Thymic and bursal atrophy
	956	11*	(0)	Normal
	957	7*	(ND)	(ND)
	958	11	(0)	Normal
	959	11	(1) Liver nodes	Normal
	960	11	(0)	Normal
	961	11	(1) Ovary	Thymic, splenic, and bursal atrophy
	962	11	(1) Ovary, liver, rate, and eyes	Thymic and splenic atrophy
T5 "contact" chickens	963	11	(1) Heart, lung, liver, and ovary	Thymic, splenic, and bursal atrophy
	964	11	(1) Ovary	Normal
	965	11	(1) Ovary, pancreas, liver, and oesophagus	(ND)
	966	10*	(ND)	(ND)
	967	11	(1) Ovary	(ND)
	968	11	(0)	Normal
Early T9 inoculated chickens	475	6	(1) Testis, nerves	Thymic, splenic, and bursal atrophy
	476	6	(1) Ovary, lung	Thymic, splenic, and bursal atrophy
	477	6*	(1) Kidney, liver	Thymic and bursal atrophy
	478	6*	(1) Ovary	Thymic and bursal atrophy
	479	8	(1) Ovary	(ND)
	480	8	(1) Ovary	(ND)
	481	8	(1) Skin, nerves, and nodes in the gut	(ND)
	482	8	(1) Testis, muscle	(ND)
	483	6	(1) Testis	(ND)
	Early T9 "contact" chickens	484	6*	(ND)
485		9*	(1) Lung, ovary	Thymic, splenic, and bursal atrophy
486		9*	(1) Ovary	Thymic, splenic, and bursal atrophy
487		11*	(1) Ovary	(ND)
488		13*	(1) Ovary	(ND)
489		6*	(1) Ovary	Thymic and bursal atrophy

(0) and (1) indicate the absence or presence of tumours, respectively. All inoculations were carried out by intraperitoneal injections of 10^7 cells. *Chickens were sacrificed at the week indicated but in some cases they died before. ND, none determined.

These results indicated that the 5' BamHI-A fragment containing the ICP4 gene is also disrupted in late T9 cells. As revealed by the detection of an additional 6.8 kb fragment, the 5' BamHI-A fragment is rearranged in early T9 cells. From the size of this fragment and the origin of the probe, the rearrangement in early T9 cells maps within the promoter of the ICP4 gene between the EcoRI and PvuII restriction sites (positions 11193 and 7750, respectively; numbering according to McKie and colleagues⁴⁶).

Expression of the meq gene in the MDV cell lines

The Eco-Q fragment of the MDV genome encompasses the 3' end of the BamHI-I2 and BamHI-Q2 fragments. It contains an ORF referred to as meq.²⁴

In MDV transformed cells, Southern blotting performed with the meq probe detected a 5.1 kb and a 1.3 kb EcoRI (fig 5, left hand panel) and a 2.7 kb BamHI fragment (fig 5, right hand panel), respectively. The sizes of these fragments were in agreement with the previously published nucleotide sequence.²⁴

Wilson *et al* have reported that the reduced expression of MDV gC in attenuated strains did not result from structural alterations within or near that gene, and suggested that gene(s) encoding MDV regulatory protein(s) that interact with the MDV gC promoter might be altered during the attenuation process.⁴⁷ The Eco-Q region expression pattern was established following northern blot hybridisation with the meq DNA probe. At least five transcripts with sizes ranging from 1.4, 1.8, 2.1, and 2.5 to 3.1 kb were detected in all the MDV cell lines (fig 6). Only minor differences in the degree of expression of these different species could be seen among RNA from these cell lines. This result was consistent with previous work reporting the expression of both spliced and

unspliced sense transcripts in addition to antisense transcripts from the BamHI-I2/Q2 region encoding MEQ.^{24 48-50}

Immunoblotting performed with a polyclonal MEQ antibody²⁷ revealed proteins of 31, 54, and 57 kDa in all cell extracts (fig 7). An additional 74–80 kDa doublet was specifically detected in MSB1, T5, and the early and late T9 cell extracts. The apparent molecular weight of these MEQ proteins was higher than those described previously.^{24 50} Liu and colleagues²⁷ reported that the MEQ protein migrated with an apparent molecular weight ranging from 50 to 75 kDa, depending upon the origin of the cell lines analysed. These discrepancies may result from post-translational modifications, such as phosphorylation. Alternatively spliced MEQ RNA species also contribute to the variation in apparent sizes of the MEQ proteins.⁴⁹

Pathogenicity of the MDV cell lines in vivo

Marek's disease can be experimentally induced by the injection of MDV lymphoblastoid cell lines into susceptible birds. To determine whether early and late T9 cells were still able to induce Marek's disease, 10^7 cells were injected intraperitoneally into 1 day old chickens. The T5 cell line was used as a positive control.

Chickens injected with either T5 or early T9 cells developed classic signs of Marek's disease (paralysis; table 1). Furthermore, contact exposed chickens developed signs of Marek's disease, therefore confirming the horizontal transmission of infectious virus. Necropsy frequently revealed macroscopic tumours and bursal and thymic atrophy in either inoculated or contact exposed chickens. Lymphoid tumours were localised mainly to the sexual organs, but occasionally arose in liver, kidney, heart, and proventriculus (table 2). The sexual localisation appeared to be a characteristic of the oncogenic HPRS16

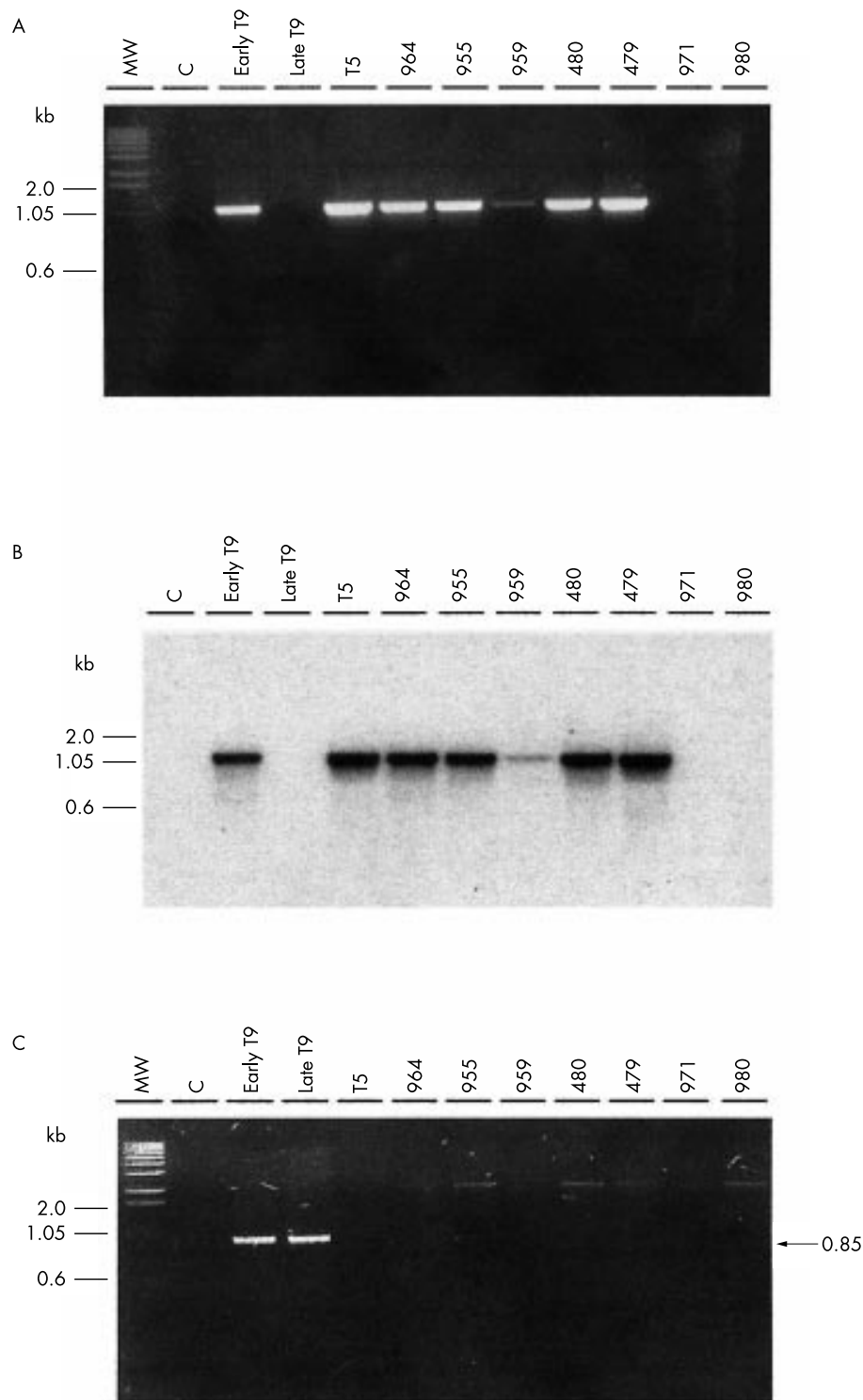

Figure 8 Molecular analysis of the tumours (or normal tissues) isolated from T5, early T9, and late T9 cell line inoculated and contact chickens. (A) Detection of Marek's disease virus (MDV) sequences in DNA from induced tumours. PCR amplification was carried out on DNA isolated from different tissues of chickens injected with T5 (964, 955, and 959), early T9 (479 and 480), and late T9 (971 and 980). The control without DNA template (lane C) was performed under identical conditions. Additional controls included DNA isolated from the early T9, late T9, and T5 cell lines. PCR products were run on a 1.5% agarose gel and visualised with an ultraviolet transilluminator. The positions of selected bands from a 1 kb ladder marker (BRL) are indicated on the left. (B) PCR products run on the gel were transferred on to a nitrocellulose membrane and then hybridised with [³²P] labelled oligonucleotides pp381. (C) PCR amplification of the 5' RAV-c-myb junction. The same DNA templates as in (A) were subjected to 30 rounds of amplification using primer 1 (corresponding to c-myb exon 3 sequences) and primer 2 (corresponding to RAV gag sequences).³² PCR products were run on a 1.5% agarose gel and visualised by means of an ultraviolet transilluminator. The position of the PCR amplified 850 bp 5' junction fragment is indicated. Control experiments were performed under identical conditions without DNA (lane C).

strain of MDV.⁵¹ Histological examination revealed lymphocytic infiltration of peripheral nerves in all the chickens examined (four of four for the early T9 cells and 11 of 11 for the T5 cells induced Marek's disease; data not shown).

In contrast, birds inoculated with late T9 cells or contact exposed chickens developed no signs of Marek's disease (table 1). Chickens were sacrificed at 15 weeks. Necropsy revealed no signs of bursal or thymic atrophy, splenomegaly, or tumour formation. Histological examination of peripheral nerves confirmed the absence of Marek's disease lesions (data not shown).

To confirm that injected birds indeed carried MDV genomes, total cellular DNA isolated from tumours was used as template for PCR amplification. Consistent with the presence of MDV DNA sequences, a 1.0 kb product was amplified with a primer set for the pp38 gene (fig 1) using DNA isolated from spleen, liver, and ovary of chickens injected with early T9 and T5 cell lines (fig 8A). A 1.0 kb product was also amplified from a contact chicken, indicating that inoculated chickens produced viruses that could infect neighbouring chickens. No amplification product was obtained with DNA from late T9 cell injected chickens (fig 8A). The origin of the amplified product was confirmed by probing with the pp38I labelled oligonucleotide (fig 8B).

To establish whether tumours arising in T9 infected birds originate from an expansion of the injected tumour cells or from MDV induced transformation, we took advantage of the previously reported activation of c-myc in T9 cells³² and performed MHC typing. Using primers specific for the 5' myb-RAV junction in T9 cells³² no products were amplified from DNA derived from either early T9 induced tumours or tissues from late T9 inoculated chickens (fig 8C). Positive and negative controls were performed with late and early T9 and T5 cells, respectively. PCR-single stranded conformational polymorphism experiments performed with different sets of primers specific for the YF gene from the MHC class I established that tumoral cells exhibited the same pattern as that of the recipient chicken. This pattern was different from that of T5, early T9, and late T9 cells (data not shown). These results indicated that tumour formation in injected animals did not result from the proliferation of early T9 or T5 cells, but from the transformation of chicken recipient lymphoid cells by MDV.

DISCUSSION

We have previously reported that the MDV transformed T9 lymphoblastoid cell line contained a RAV insertional activation of c-myc and a rearranged MDV genome lacking the BamHI-H fragment. To establish the relative participation of the MDV and myb sequences in the transformed phenotype of the T9 cells, we analysed them for the presence of MDV oncogenic sequences. We have focused our analysis on the following potential oncogenic regions: the BamHI-H, BamHI-A, and Eco-Q fragments, which encode the pp38 and the 1.8 kb RNA family; the ICP4 homologue transcriptional factor; and meq.⁵²⁻⁵⁴ Genomic analysis revealed that all these fragments were apparently intact in the early T9 cells and expression patterns from these regions were identical to those from the MSB1 prototype cell line and T5 cells, which express infectious transforming MDV. Conversely, the BamHI-H fragment and the ICP4 coding region were rearranged in the late T9 cells. In vivo experiments confirmed that these alterations abrogated the capacity of the late T9 cell line to induce Marek's disease in chickens.

The loss of the BamHI-H fragment in late T9 cells is reminiscent of the situation encountered in attenuated strains obtained after serial passage of virulent MDV strains in primary CEF.⁷ Because no alteration of this region occurred upon repeated passages of the early T9 cells (not shown), the rearrangement of this region in late T9 cells must have involved another mechanism. Moreover, an additional, less intense fragment was revealed with the ICP4 probe in the early T9 cells that could result from rearrangement in progress

in a subpopulation of cells. Hayashi and colleagues⁵⁵ have previously described an amplification of a 178 bp repeat sequence within the 1.6 kb HindIII subfragment of BamHI-A in viral DNA isolated from both pathogenic and non-pathogenic strains, and in established lymphoblastic cells. In this last case, the 178 bp expansions mapped about 1 kb downstream of the stop codon of the ICP4 gene, giving rise to heterogeneity of IR_s and TR_s. In contrast, alteration in early T9 cells seems to take place in the ICP4 promoter region without revealing heterogeneity accounted for expansions. The expression of ICP4 is down regulated by the LATs during latency and the balance between the sense (ICP4) and antisense transcripts may serve as a switch to turn off MDV replication during latency.²⁰ The lack of the ICP4 and LAT coding regions in the late T9 cell line may totally abrogate reactivation of the virus. Because an ori sequence is found in the bidirectional promoter of pp38 and the 1.8 kb family RNA gene (BamHI-H), it is likely that in the late T9 cells MDV is unable to replicate.⁵⁶⁻⁵⁸ Indeed, immunodiffusion performed with blood samples from chickens inoculated with late T9 cells did not reveal antibody against MDV (data not shown), confirming the fact that late T9 cells did not produce infectious viruses and were no longer capable of inducing Marek's disease.

"Because MEQ was the only MDV oncogene fully expressed in the late T9 cells, our results raise questions regarding the factors involved in the maintenance of the transformed phenotype in these cells"

Deletions and expansions of tandem repeats were reported to occur concurrently with attenuation of oncogenic MDV strains upon extensive passages in primary CEFs.^{7 47 59 60} Usually, MDV lymphoblastoid cells are immortalised cell lines, which are latently infected with MDV,^{61 62} and capable of transferring MDV to CEFs or duck embryo fibroblasts in vitro. Despite many years in culture, these cell lines are still able to induce Marek's disease in susceptible birds. Repeatedly passaged T9 cells might have selected cells containing deletion of the BamHI-H and the ICP4 encoding region in their MDV genome and other gross structural alterations that were not detected in our study. The relative instability of the MDV genome in these cells could result from insertion and excision events mediated by RAV-1 and homologous recombination between long terminal repeat sequences because it has been reported that the MDV genome often undergoes structural changes, including insertions of retroviral elements.^{4 63-66} Identification and sequencing of junction sites at the border of these deletions could help in elucidating the mechanism involved in the disruption of the MDV sequences in late T9 cells.

Because MEQ was the only MDV oncogene fully expressed in the late T9 cells, our results raise questions regarding the factors involved in the maintenance of the transformed phenotype in these cells. We have previously shown that T9 cells expressed high amounts of a truncated MYB protein as a result of RAV-1 integration within the c-myc allele.³² A similar truncation conferred a transforming potential on myb, when assessed in primary chicken fibroblasts,⁶⁷ and related chimaeric mRNA was isolated from B lymphomas and fibrosarcomas induced by avian leukosis virus.⁶⁸ To our knowledge, this is the only report of a RAV insertional activation of c-myc in a T lymphoma. Liu *et al* reported that MEQ can transform established Rat-2 fibroblasts but MEQ alone is not capable of transforming primary cells.²⁷ Furthermore, recombinant retroviruses carrying meq yield a low incidence of sarcomas, indicating that meq is a weak oncogene,²⁷ and that meq may require additional cooperating oncogenes to display its full transforming activity. At least four MDV genes (pp38, ICP4, meq, and the 1.8 kb RNA family) have been shown to be important for the maintenance of the transformed phenotype

Take home messages

- Longterm culture of a Marek's disease virus (MDV) transformed cell line (late T9) containing a RAV insertional activation of the c-myc protooncogene led to the disruption of the MDV BamHI-H and BamHI-A oncogenic regions and MEQ was the only detected MDV oncoprotein in these cells
- In late T9 cells, it is possible that the truncated MYB protein compensates for the loss of MDV oncoproteins
- In addition, it is possible that the maintenance of transformation in this cell line may require MEQ and MYB

in MSB1 cells.¹⁸ Because meq expression is detected in late T9 cells, we speculate that the activation of c-myc might compensate for the lack of MDV genes and act synergistically with meq to maintain the transformed phenotype in late T9 cells.

To determine whether the expression of both the MEQ and truncated MYB proteins is required for the maintenance of the transformed phenotype, we have engineered T9 cells that express antisense mRNA using the pMDL7 inducible vector (pMD221 for meq antisense¹⁸ and pMDmyb, our construct). In contrast to Morgan's laboratory, we failed to establish antisense expressing cell lines, but we were able to establish control cell lines (expressing sense myb and meq). These results suggested that the inhibition of meq or myb expression might interfere with T9 cell proliferation; an observation in favour of a role for both the MYB and MEQ oncoproteins in the maintenance of the transformed phenotype. Another antisense strategy should be explored to determine the subtle contribution of activated myb and/or meq in this phenotype. Nonetheless, our results indicate that T9 cells constitute a cellular model to identify the meq target genes in the context of cells carrying a defective MDV genome.

ACKNOWLEDGEMENTS

We are grateful to Dr F Colbere-Garapin for critical reading of the manuscript. The pBamHI-H used in this study was kindly provided by Dr N Ross and the anti-MEQ polyclonal antibody by H-J Kung and L Lee. We thank Dr J-L Liu for helpful comments about western blotting and Dr R Morgan for providing the pMD vectors. Part of this study was performed when the "Laboratoire d'Oncologie Virale et Moléculaire" was affiliated to the CNRS-UMR146 at the Institut Curie. This research was funded by grants to BP from Association pour la Recherche contre le Cancer (ARC), Ligue Nationale Contre le Cancer (LNCC), and Fondation de France. ELR was supported by a fellowship from Société Française d'Hématologie.

Authors' affiliations

E Le Rouzic, B Perbal, Laboratoire d'Oncologie Virale et Moléculaire, UFR de Biochimie, Université Paris 7-D. Diderot, Paris, France
P Thoraval, M Afanassieff, G Dambrine, INRA Tours, Station de Pathologie Aviaire et Parasitologie, 37380 Nouzilly, France
Y Cherel, Ecole Nationale Vétérinaire, INRA UR703, 44307 Nantes, Cedex 03, France

REFERENCES

- 1 **Biggs PM**. The Leeuwenhoek Lecture. Marek's disease herpesvirus: oncogenesis and prevention. *Philos Trans R Soc Lond B Biol Sci* 1997;**352**:1951-62.
- 2 **Fukuchi K**, Sudo M, Lee Y, *et al*. Structure of Marek's disease virus DNA: detailed restriction enzyme map. *J Virol* 1984;**51**:1102-9.
- 3 **Tulman ER**, Alfonso CL, Lu Z, *et al*. The genome of a very virulent Marek's disease virus. *J Virol* 2000;**74**:7980-8.
- 4 **Lee LF**, Wu P, Sui D, *et al*. The complete unique long sequence and the overall genomic organization of the GA strain of Marek's disease virus. *Proc Natl Acad Sci U S A* 2000;**97**:6091-6.
- 5 **Ross NL**. T-cell transformation by Marek's disease virus. *Trends Microbiol* 1999;**7**:22-9.
- 6 **Churchill AE**, Chubb RC, Baxendale W. The attenuation with loss of oncogenicity of the herpes-type virus of Marek's disease virus (strain HPRS-16) on passage in cell culture. *J Gen Virol* 1969;**4**:557-564.
- 7 **Fukuchi K**, Tanaka A, Schierman LW, *et al*. The structure of Marek disease virus DNA: the presence of unique expansion in nonpathogenic viral DNA. *Proc Natl Acad Sci U S A* 1985;**82**:751-4.
- 8 **Silva RF**, Witter RL. Genomic expansion of Marek's disease virus DNA is associated with serial in vitro passage. *J Virol* 1985;**54**:690-6.
- 9 **Maotani K**, Kanamori A, Ikuta K, *et al*. Amplification of a tandem direct repeat within inverted repeats of Marek's disease virus DNA during serial in vitro passage. *J Virol* 1986;**58**:657-60.
- 10 **Ross N**, Binns MM, Sanderson M, *et al*. Alterations in DNA sequence and RNA transcription of the Bam HI-H fragment accompany attenuation of oncogenic Marek's disease herpesvirus. *Virus Genes* 1993;**7**:33-51.
- 11 **Bradley G**, Lancz G, Tanaka A, *et al*. Loss of Marek's disease virus tumorigenicity is associated with truncation of RNAs transcribed within BamHI-H. *J Virol* 1989;**63**:4129-35.
- 12 **Kawamura M**, Hayashi M, Furuchi T, *et al*. The inhibitory effects of oligonucleotides, complementary to Marek's disease virus mRNA transcribed from the BamHI-H region, on the proliferation of transformed lymphoblastoid cells, MDCC-MSB1. *J Gen Virol* 1991;**72**:1105-11.
- 13 **Peng F**, Donovan J, Specter S, *et al*. Prolonged proliferation of primary chicken embryo fibroblasts transfected with cDNAs from the BamHI-H gene family of Marek's disease virus. *Int J Oncol* 1993;**3**:85-94.
- 14 **Peng F**, Specter S, Tanaka A, *et al*. A 7 kDa protein encoded by the BamHI-H gene family of Marek's disease virus is produced in lytically and latently infected cells. *Int J Oncol* 1994;**4**:799-802.
- 15 **Hong Y**, Coussens PM. Identification of an immediate-early gene in the Marek's disease virus long internal repeat region which encodes a unique 14-kilodalton polypeptide. *J Virol* 1994;**68**:3593-603.
- 16 **Zhu GS**, Iwata A, Gong M, *et al*. Marek's disease virus type 1-specific phosphorylated proteins pp38 and pp24 with common amino acid termini are encoded from the opposite junction regions between the long unique and inverted repeat sequences of viral genome. *Virology* 1994;**200**:816-20.
- 17 **Chen X**, Velicer LF. Expression of the Marek's disease virus homolog of herpes simplex virus glycoprotein B in *Escherichia coli* and its identification as B antigen. *J Virol* 1992;**66**:4390-8.
- 18 **Xie Q**, Anderson AS, Morgan RW. Marek's disease virus (MDV) ICP4, pp38, and meq genes are involved in the maintenance of transformation of MDCC-MSB1 MDV-transformed lymphoblastoid cells. *J Virol* 1996;**70**:1125-31.
- 19 **Anderson AS**, Francesconi A, Morgan RW. Complete nucleotide sequence of the Marek's disease virus ICP4 gene. *Virology* 1992;**189**:657-67.
- 20 **Abujoub AA**, Coussens PM. Evidence that Marek's disease virus exists in a latent state in a sustainable fibroblast cell line. *Virology* 1997;**229**:309-21.
- 21 **Cantello JL**, Anderson AS, Morgan RW. Identification of latency-associated transcripts that map antisense to the ICP4 homolog gene of Marek's disease virus. *J Virol* 1994;**68**:6280-90.
- 22 **Cantello JL**, Parcels MS, Anderson AS, *et al*. Marek's disease virus latency-associated transcripts belong to a family of spliced RNAs that are antisense to the ICP4 homolog gene. *J Virol* 1997;**71**:1353-61.
- 23 **Li DS**, Pastorek J, Zelnik V, *et al*. Identification of novel transcripts complementary to the Marek's disease virus homologue of the ICP4 gene of herpes simplex virus. *J Gen Virol* 1994;**75**:1713-22.
- 24 **Jones D**, Lee L, Liu JL, *et al*. Marek disease virus encodes a basic-leucine zipper gene resembling the fos/jun oncogenes that is highly expressed in lymphoblastoid tumors [published erratum appears in *Proc Natl Acad Sci U S A* 1993;**90**:2556]. *Proc Natl Acad Sci U S A* 1992;**89**:4042-6.
- 25 **Liu JL**, Lee LF, Ye Y, *et al*. Nucleolar and nuclear localization properties of a herpesvirus bZIP oncoprotein, MEQ. *J Virol* 1997;**71**:3188-96.
- 26 **Ross N**, O'Sullivan G, Rothwell C, *et al*. Marek's disease virus EcoRI-Q gene (meq) and a small RNA antisense to ICP4 are abundantly expressed in CD4+ cells and cells carrying a novel lymphoid marker, AV37, in Marek's disease lymphomas. *J Gen Virol* 1997;**78**:2191-8.
- 27 **Liu JL**, Ye Y, Lee LF, *et al*. Transforming potential of the herpesvirus oncoprotein MEQ: morphological transformation, serum-independent growth, and inhibition of apoptosis. *J Virol* 1998;**72**:388-95.
- 28 **Liu JL**, Ye Y, Qian Z, *et al*. Functional interactions between herpesvirus oncoprotein MEQ and cell cycle regulator CDK2. *J Virol* 1999;**73**:4208-19.
- 29 **Qian Z**, Brunovskis P, Rauscher F, 3rd, *et al*. Transactivation activity of Meq, a Marek's disease herpesvirus bZIP protein persistently expressed in latently infected transformed T cells. *J Virol* 1995;**69**:4037-44.
- 30 **Qian Z**, Brunovskis P, Lee L, *et al*. Novel DNA binding specificities of a putative herpesvirus bZIP oncoprotein. *J Virol* 1996;**70**:7161-70.
- 31 **Pratt WD**, Cantello J, Morgan RW, *et al*. Enhanced expression of the Marek's disease virus-specific phosphoproteins after stable transfection of MSB-1 cells with the Marek's disease virus homologue of ICP4. *Virology* 1994;**201**:132-6.
- 32 **Le Rouzic E**, Perbal B. Retroviral insertional activation of the c-myc proto-oncogene in a Marek's disease T-lymphoma cell line. *J Virol* 1996;**70**:7414-23.
- 33 **Mazzella O**, Cauchy L, Coudert F, *et al*. Chicken thymocyte-specific antigens identified by monoclonal antibodies: characterization and distribution in normal tissues and in tumoral tissues from Marek's disease chicken. *Hybridoma* 1986;**5**:319-28.
- 34 **Quérel P**, Dambrine G. Development of anti-tumoral cell-mediated cytotoxicity during the course of Marek's disease in chickens. *Ann Rech Vet* 1988;**19**:193-201.
- 35 **Akiyama Y**, Kato S. Two cell lines from lymphomas of Marek's disease. *Biken J* 1974;**17**:105-16.
- 36 **Powell PC**, Payne LN, Frazier JA, *et al*. T lymphoblastoid cell lines from Marek's disease lymphomas. *Nature* 1974;**251**:79-80.
- 37 **Okazaki W**, Witter RL, Romero R, *et al*. Induction of lymphoblastoid leukemia transplantable tumors and the establishment of lymphoblastoid cell lines. *Avian Pathol* 1980;**9**:311-29.

- 38 **Moscovici C**, Zeller N, Moscovici G. Continuous lines of AMV-transformed non-producer cells: growth and oncogenic potential in the chick embryo. In: Revoltella RF, Pontieri GM, Basilio C, *et al*, eds. *Expression of differentiated functions in cancer cells*. New York: Raven Press, 1982:435–49.
- 39 **Soret J**, Kryceve-Martinerie C, Crochet J, *et al*. Transformation of brown leghorn chicken embryo fibroblasts by avian myeloblastosis virus proviral DNA. *J Virol* 1985;**55**:193–205.
- 40 **Bacon LD**, Schierman LW, McBride RA. Alloimmune hemolytic plaque-forming cells: kinetics of IgM and IgG alloantibody releasing cells during a primary and secondary immune response of chickens. *J Immunol* 1972;**109**:207–16.
- 41 **Perbal B**. *A practical guide to molecular cloning*, 2nd ed. New York: John Wiley & Sons, 1988.
- 42 **Bregni M**, Magni M, Siena S, *et al*. Human peripheral blood hematopoietic progenitors are optimal targets of retroviral-mediated gene transfer. *Blood* 1992;**80**:1418–22.
- 43 **Banders UT**, Coussens PM. Interactions between Marek's disease virus encoded or induced factors and the Rous sarcoma virus long terminal repeat promoter. *Virology* 1994;**199**:1–10.
- 44 **MacLeod AR**. Expression of the mRNA coding for glyceraldehyde-3-phosphate dehydrogenase. *Eur J Biochem* 1981;**119**:353–8.
- 45 **Ross LJ**, Binns MM, Tyers P, *et al*. Construction and properties of a turkey herpesvirus recombinant expressing the Marek's disease virus homologue of glycoprotein B of herpes simplex virus. *J Gen Virol* 1993;**74**:371–7.
- 46 **McKie EA**, Ubukata E, Hasegawa S, *et al*. The transcripts from the sequences flanking the short component of Marek's disease virus during latent infection form a unique family of 3'-coterminal RNAs. *J Virol* 1995;**69**:1310–14.
- 47 **Wilson MR**, Southwick RA, Pulaski JT, *et al*. Molecular analysis of the glycoprotein C-negative phenotype of attenuated Marek's disease virus. *Virology* 1994;**199**:393–402.
- 48 **Peng Q**, Shirazi Y. Isolation and characterization of Marek's disease virus (MDV) cDNAs from a MDV-transformed lymphoblastoid cell line: identification of an open reading frame antisense to the MDV Eco-Q protein (Meq). *Virology* 1996;**221**:368–74.
- 49 **Peng Q**, Shirazi Y. Characterization of the protein product encoded by a splicing variant of the Marek's disease virus Eco-Q gene (Meq). *Virology* 1996;**226**:77–82.
- 50 **Peng Q**, Zeng M, Bhuiyan ZA, *et al*. Isolation and characterization of Marek's disease virus (MDV) cDNAs mapping to the BamHI2, BamHI-Q2, and BamHI-L fragments of the MDV genome from lymphoblastoid cells transformed and persistently infected with MDV. *Virology* 1995;**213**:590–9.
- 51 **Purchase HG**, Biggs PM. Characterization of five isolates of Marek's disease. *Res Vet Sci* 1967;**8**:440–9.
- 52 **Kung HJ**, Tanaka A, Nonoyama M. Two gene families of Marek's disease virus (MDV) with a potential role in tumor induction in chicken. *Int J Oncol* 1995;**6**:997–1002.
- 53 **Venugopal K**. Marek's disease: an update on oncogenic mechanisms and control. *Res Vet Sci* 2000;**69**:17–23.
- 54 **Kung HJ**, Xia L, Brunovskis P, *et al*. Meq: an MDV-specific bZIP transactivator with transforming properties. *Curr Top Microbiol Immunol* 2001;**255**:245–60.
- 55 **Hayashi M**, Jessip J, Fukuchi K, *et al*. The structure of Marek's disease virus DNA: amplification of repeat sequence in IRs and TRs. *Microbiol Immunol* 1988;**32**:265–74.
- 56 **Bradley G**, Hayashi M, Lancz G, *et al*. Structure of the Marek's disease virus BamHI-H gene family: genes of putative importance for tumor induction. *J Virol* 1989;**63**:2534–42.
- 57 **Katsumata A**, Iwata A, Ueda S. Cis-acting elements in the lytic origin of DNA replication of Marek's disease virus type 1. *J Gen Virol* 1998;**79**:3015–18.
- 58 **Morgan RW**, Cantello JL, Claessens JA, *et al*. Inhibition of Marek's disease virus DNA transfection by a sequence containing an alphaherpesvirus origin of replication and flanking transcriptional regulatory elements. *Avian Dis* 1991;**35**:70–81.
- 59 **van Iddekinge BJ**, Stenzler L, Schat KA, *et al*. Genome analysis of Marek's disease virus strain CVI-988: effect of cell culture passage on the inverted repeat regions. *Avian Dis* 1999;**43**:182–8.
- 60 **Wilson MR**, Coussens PM. Purification and characterization of infectious Marek's disease virus genomes using pulsed field electrophoresis. *Virology* 1991;**185**:673–80.
- 61 **Delecluse HJ**, Schuller S, Hammerschmidt W. Latent Marek's disease virus can be activated from its chromosomally integrated state in herpesvirus-transformed lymphoma cells. *EMBO J* 1993;**12**:3277–86.
- 62 **Delecluse HJ**, Hammerschmidt W. Status of Marek's disease virus in established lymphoma cell lines: herpesvirus integration is common. *J Virol* 1993;**67**:82–92.
- 63 **Isfort RJ**, Qian Z, Jones D, *et al*. Integration of multiple chicken retroviruses into multiple chicken herpesviruses: herpesviral gD as a common target of integration. *Virology* 1994;**203**:125–33.
- 64 **Isfort R**, Jones D, Kost R, *et al*. Retrovirus insertion into herpesvirus in vitro and in vivo. *Proc Natl Acad Sci U S A* 1992;**89**:991–5.
- 65 **Witter RL**, Li D, Jones D, *et al*. Retroviral insertional mutagenesis of a herpesvirus: a Marek's disease virus mutant attenuated for oncogenicity but not for immunosuppression or in vivo replication. *Avian Dis* 1997;**41**:407–21.
- 66 **Sakaguchi M**, Sonoda K, Matsuo K, *et al*. Insertion of tandem direct repeats consisting of avian leukosis virus LTR sequences into the inverted repeat region of Marek's disease virus type 1 DNA. *Virus Genes* 1997;**14**:157–62.
- 67 **Dini PW**, Lipsick JS. Oncogenic truncation of the first repeat of c-Myb decreases DNA binding in vitro and in vivo. *Mol Cell Biol* 1993;**13**:7334–48.
- 68 **Press RD**, Kim A, Ewert DL, *et al*. Transformation of chicken myelomonocytic cells by a retrovirus expressing the v-myb oncogene from the long terminal repeats of avian myeloblastosis virus but not Rous sarcoma virus. *J Virol* 1992;**66**:5373–83.

CORRECTION

Paroxysmal nocturnal haemoglobinuria: Nature's gene therapy? R J Johnson, P Hillmen *Mol Pathol* 2002;**55**:145–52.

The authors' affiliations were missing from the above paper. They are as follows: R J Johnson, Department of Haematology, Birmingham Heartlands Hospital, Bordesley Green East, Birmingham B9 5SS, UK; P Hillmen, Haematological Malignancy Diagnostic Service, the General Infirmary at Leeds, Great George Street, Leeds LS1 3EX, UK.



Alterations of the MDV oncogenic regions in an MDV transformed lymphoblastoid cell line

E Le Rouzic, P Thoraval, M Afanassieff, et al.

Mol Path 2002 55: 262-272
doi: 10.1136/mp.55.4.262

Updated information and services can be found at:
<http://mp.bmj.com/content/55/4/262.full.html>

References

These include:

This article cites 65 articles, 35 of which can be accessed free at:
<http://mp.bmj.com/content/55/4/262.full.html#ref-list-1>

Article cited in:
<http://mp.bmj.com/content/55/4/262.full.html#related-urls>

Email alerting service

Receive free email alerts when new articles cite this article. Sign up in the box at the top right corner of the online article.

Notes

To request permissions go to:
<http://group.bmj.com/group/rights-licensing/permissions>

To order reprints go to:
<http://journals.bmj.com/cgi/reprintform>

To subscribe to BMJ go to:
<http://group.bmj.com/subscribe/>